



# NextPM Technical Note

Communicate with NextPM using RS485 Modbus protocol

Manufactured by



Last update : 2021/06/05

Distributed by



Version : 2.1

Author : A. DUMAS (TERA Sensor)



## SUMMARY

<b>1. Introduction</b>	<b>Page 3</b>
<b>2. General</b>	<b>Page 3</b>
<b>3. Configurations</b>	<b>Page 4-6</b>
3.1) Full duplex communication	4
3.2) Half duplex communication	5
<b>4. Bill of Materials</b>	<b>Page 7</b>
<b>5. Example</b>	<b>Page 7</b>

**Distributed by: ION Science Ltd**  
The Hive, Butts Lane, Fowlmere, Cambridgeshire, SG8 7SL, UK

T: +44 (0)1763 208503  
E: [sensors@ionscience.com](mailto:sensors@ionscience.com)  
W: [ionscience.com](http://ionscience.com)

## 1. Introduction

NextPM is able to communicate with the Modbus protocol.

However, it does not have the electronics to provide the necessary voltages on an RS485 network.

A board must be added at the output of NextPM, we have tested Digilent's PmodRS485 module, which allows full and half duplex communication.

This document will describe one way to realize your own board to communicate with NextPM on a RS485 network.

## 2. General

The main component you need to communicate with NextPM is a converter. This converter will change the serial communication of NextPM into RS485. For that purpose, we advise you to use the PmodRS485 module. This module can be used in two different configurations to communicate with the NextPM, in half duplex and full duplex.

Note that in half duplex, the Chip Select function of NextPM is no longer available because it is used to drive the PmodRS485 module.

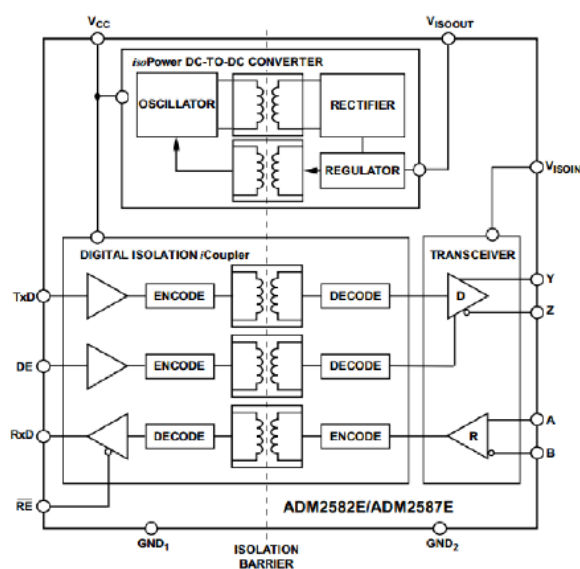
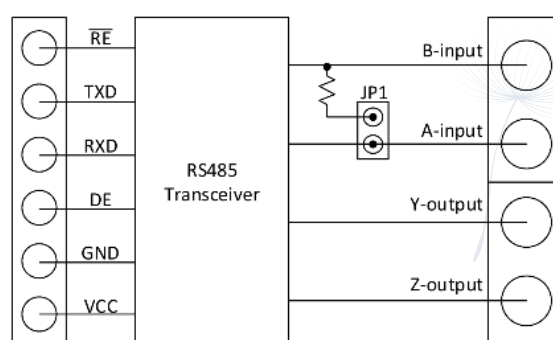

Figure 1 : PmodRS485 functional block diagram



The address of NextPM on the Modbus is initially set to 01.

The firmware of NextPM compatible with RS485 must have a version higher than 4096 in decimal or 0x1000 in hexadecimal.

This firmware also allows to change the Modbus address of NextPM on the network.

## 3. Configurations

### 3.1) Full duplex communication

Full duplex communication is carried out over 4 wires :

A-B for reception,  
Y-Z for transmission.

- Pin RxD (3) of the PmodRS485 module must be connected to the Rx of NextPM (pin 4 on the connector).
- Pin TxD (2) of the the PmodRS485 module must be connected to the Tx of NextPM (pin 3 on the connector).
- For wiring with the RS485 network, see the document entitled: “pmodrs485\_rm.pdf” and figure 3 (full duplex).
- Pin /RE (1) of the PmodRS485 module must be connected to the ground (pin 1 or 6) of NextPM connector.
- Pin DE (4) of the PmodRS485 module must be connected to Vdc (pin 2 of NextPM connector)

The wiring of the full duplex communication is shown in figure 2 & 3.

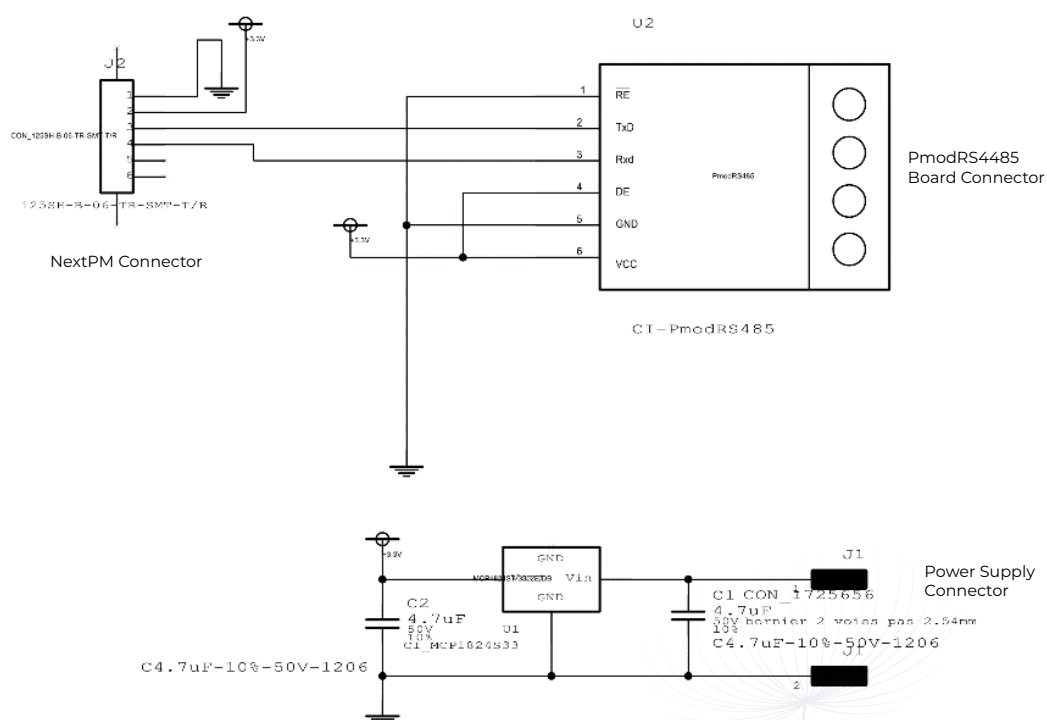
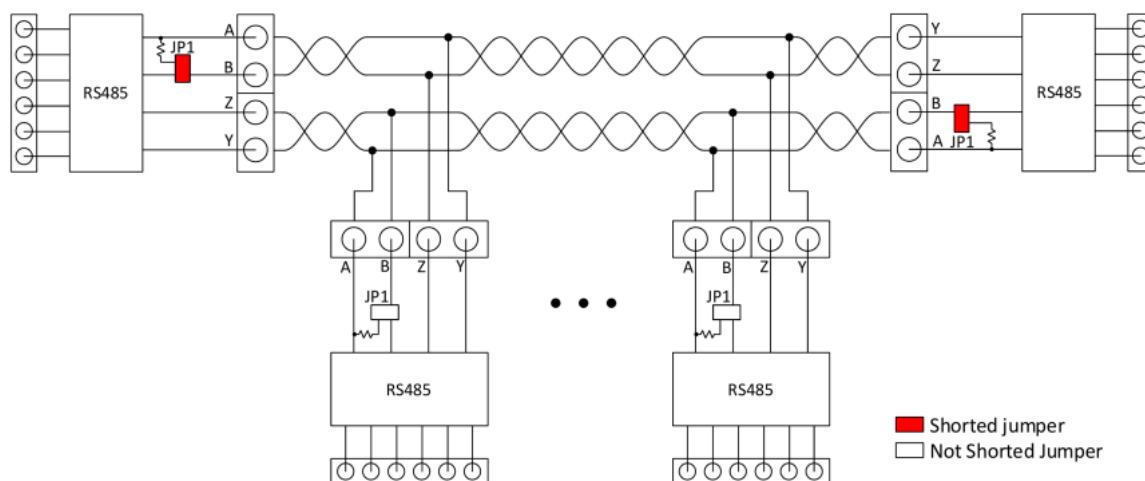

Figure 2 : Diagram of the adapter for RS485 full duplex



**Figure 3** : RS485 bus connections for full duplex communication

### 3.2) Half duplex communication

Half duplex communication is carried out over 2 wires :

A-B for reception and transmission.

- At the output of the PmodRS485 module, pins A and Y must be connected together, as well as pins B and Z (see figure 5). For wiring with the RS485 network, see also the document entitled: "pmodrs485\_rm.pdf".
- Pin RxD (3) of the PmodRS485 module must be connected to the Rx of NextPM (pin 4 on the connector).
- Pin TxD (2) of the PmodRS485 module must be connected to the Tx of NextPM (pin 3 on the connector).
- Pin /RE (1) and DE(4) of the PmodRS485 module must be connected together and to pin CS of NextPM connector (pin 5).

The wiring of the half duplex communication is shown in figure 4 & 5.

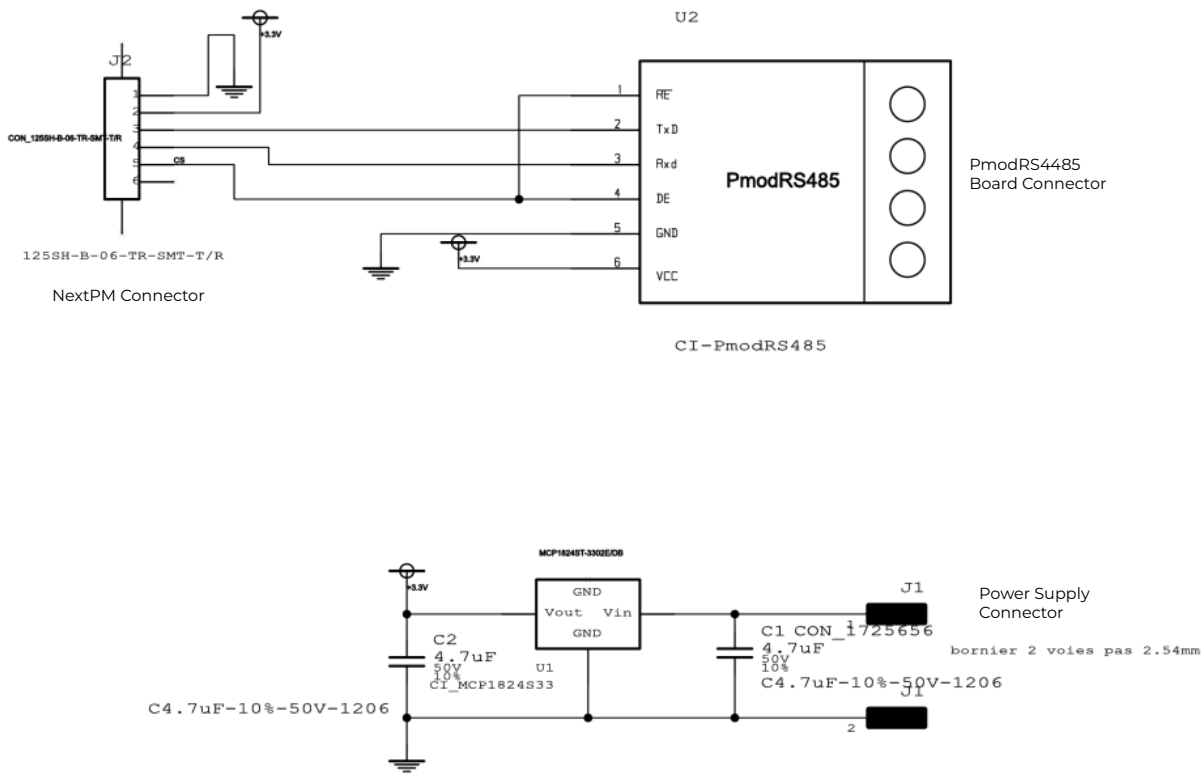

Figure 4 : Diagram of the adapter for RS485 half duplexion

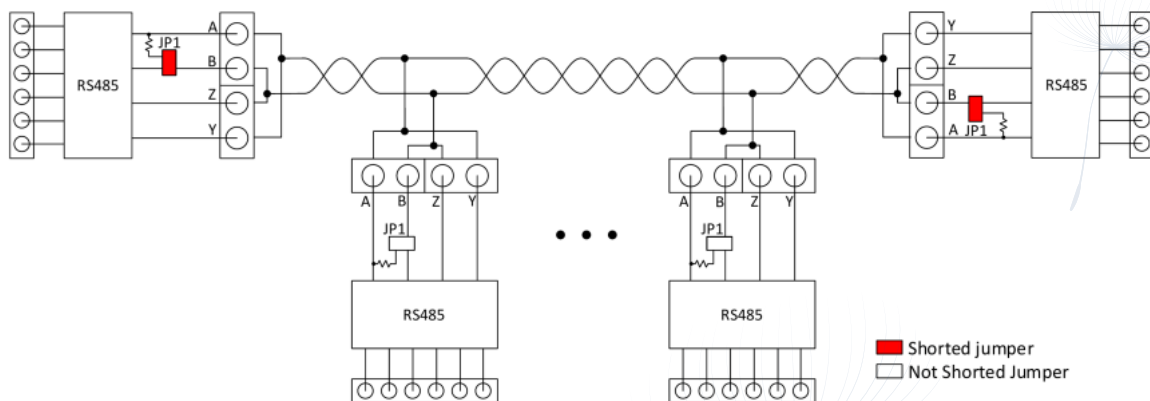

Figure 5 : Connections on the RS485 bus for half duplex communication

## 5. Bill of Materials

NextPM is able to communicate with the Modbus protocol.

However, it does not have the electronics to provide the necessary voltages on an RS485 network.

A board must be added at the output of NextPM, we have tested Digilent's PmodRS485 module, which allows full and half duplex communication.

This document will describe one way to realize your own board to communicate with NextPM on a RS485 network.

Description	Reference	Quantity
Stripe card, single-sided, 2.54 mm pitch, 100 x 160 x 1.5 mm, FR2	RS 206-5841	50x50mm
Extension module RS-485	RS 134-6474	1
Linear controller +3.3V	-	1
Capacitor 4.7 $\mu$ F	-	2
2-pin screw connector, 5.08mm pitch	RS 425-8720	1
Picoblade assembled cord, 1.25mm, 6 contacts	RS 125-0742	1
Copper wire for straps	RS 134-6474	4

It is not recommended to supply the Vdc of the PmodRS485 module with +5V. It is preferable to provide a linear regulator +5V -> +3.3V (TO220 box on the photo figure2)

## 5. Example

The following picture is an example of quick functional prototype of converting board.

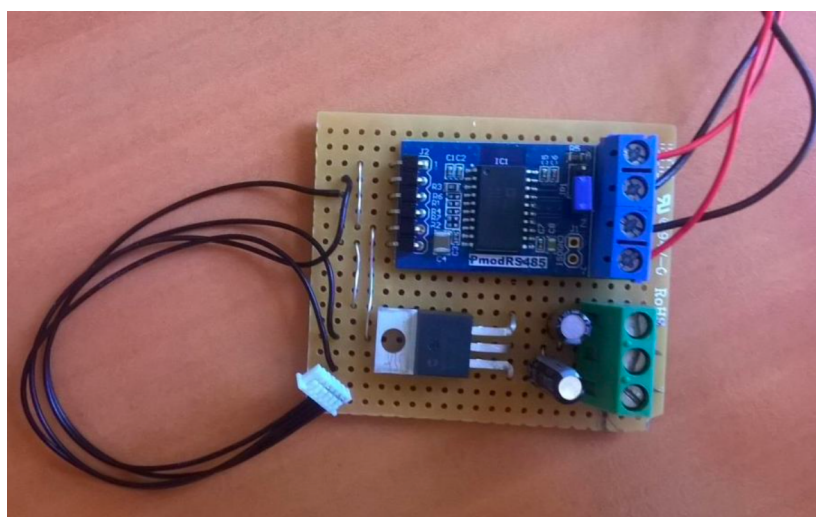

Figure 6 : Prototype example