



ARA-X4 Multi Gas Detector

Instrument User Manual V1.2





Contents

Safety	4
Legal Notices Regarding the Safe Operation of Equipment	4
Symbols	4
Warnings, Cautions and Information Notifications	4
Specific Conditions of Use	6
Disposal	6
Product Overview	7
Getting Started	7
Turning on the ARA-X4	7
Self-test	7
Main Display	8
Icons	8
Alarms	9
Safe Mode	11
Turning on the Backlight	11
Turning off the ARA-X4	12
Flip Screen	12
Menu Mode	13
Enter Password	14
Bump Test Menu	16
Calibration Menu	16
Sensor Configuration Menu	16
Alarm Settings Menu	17
Device Settings Menu	17
Quick Access Buttons	18
Language Menu	19
Diagnostics Menu	19
Device Info Menu	19
Logging Menu	20
Performing a Bump Test	20
Zeroing Sensors	20



Calibration Procedure 21

Calibration gas concentrations..... 21

Logs 21

 Bump Test Log/Calibration Log 21

 Event Log 22

 Datalog 22

Maintenance 22

 Charging the Battery 22

 Replacing sensors 23

 Replacing the Filter 26

ARA-X Manager PC Software..... 27

 Overview 27

 Connecting ARA-X4 to ARA-X Manager 27

 ARA-X4 Device Configuration 28

 ARA-X4 Sensor Configuration..... 31

 Toxic1 sensor configuration 31

 Toxic2 sensor configuration 33

 O2 Sensor Configuration 34

 LEL Sensor Configuration 35

 Creating a Device Configuration File 36

 Loading a saved Configuration File 36

 Logs 37

 Admin Login 38

 Creating an encrypted USB 40

Technical Specification..... 42

Risks, warnings and guidance when using LEL sensors..... 44

LEL sensor limitations 44

Troubleshooting 45

Accessories 46

Manual Aspirator Pump with Sample Probe – part number 926253 46

Limited Warranty..... 48

Certifications / Approvals 48

North American flammable gas performance testing: 49



Risks of working in methane environments.....49
ION Science Contact Details50

Safety

Legal Notices Regarding the Safe Operation of Equipment

- Whilst every attempt is made to ensure the accuracy of the information contained in this manual, ION Science Ltd accepts no liability for errors or omissions in the manual, or any consequences deriving from the use of information contained herein. It is provided “as is” and without any representation, term, condition or warranty of any kind, either expressed or implied.
- To the extent permitted by law, ION Science Ltd shall not be liable to any person or entity for any loss or damage which may arise from the use of this manual.
- We reserve the right at any time and without any notice to remove, amend or vary any of the content which appears in this manual.

Symbols



WARNING!

Risk of injury or death.



CAUTION

Risk of damage to equipment.



INFORMATION

Useful information, or hint about usage.



RECYCLING

Recycle all packaging.



WEEE REGULATIONS

Ensure that waste electrical equipment is disposed of correctly.

Warnings, Cautions and Information Notifications

The following warnings, cautions and information notifications apply to the product described in this manual.



This equipment must be operated and serviced by qualified personnel only.
Read this manual and follow all instructions to ensure safe use.



Do not charge the battery in hazardous locations.



Replacing components may impair Intrinsic Safety.



Some materials can permanently damage the sensor. Protect the LEL sensor from exposure to lead compounds, silicones, and chlorinated hydrocarbons.



Before daily use:

Make sure the sensor and audio ports are not blocked.

Perform the self-test to ensure the display, alarms and vibration are operating.

Check the message on the LCD display to view the result of the self-test.



Ensure that the O2 Sensor is calibrated at least every 30 days in a clean air environment. The toxic gas sensors (CO, H2S, SO2 & HCN) and LEL sensor must be calibrated every year. See the Calibration section.

Perform a bump test at least once every day. In addition, always perform a bump test if the detector has been subject to physical impact, liquid immersion, an over limit alarm event, or change of ownership, or at any time you think the detector is not working correctly.

Perform a bump test by exposing the detector to a concentration of gas that exceeds the low alarm set points. Recommended gas concentrations are:

- H2S: 25 ppm,
- CO: 100 ppm,
- SO2: 10 ppm,
- HCN: 10 ppm,
- O2: 18%,
- LEL 50%.

If the device fails the bump test, perform a calibration and retest. If the device still fails after a calibration, contact ION Science Ltd.



The combustible sensor is factory calibrated to 50% LEL methane. When monitoring other LEL gas, calibrate the sensor with the appropriate gas.



The ARA-X4 is a multi-gas detector, not a measuring device.



Read the relevant parts of this manual carefully before replacing battery, gas filter or sensors. See [Replace Components](#).



Use only an ION Science Ltd approved battery. Using unapproved batteries can risk explosion or fire.



If you suspect any malfunction or have any technical problems, contact ION Science Ltd.



Do not place the ARA-X4 close to any hot surfaces.



Use only with the specified sensors. Please refer to the sensors list at the back of this manual.



The ARA-X4 has been designed and certified Intrinsically Safe.

Specific Conditions of Use

- The charging port must only be used in safe area. The charging process must only be conducted in an environment with ambient temperature range from 0 °C to +45 °C.
- Specific conditions of use: The equipment shall only be used in an area of at least pollution degree 2 as defined in IEC/EN 60664-1

Disposal

The ARA-X4 does not include any toxic materials. However, if it has been contaminated by toxic materials, then exercise due care and follow the appropriate regulations when disposing of it.

Always adhere to local regulations and procedures when disposing of the device.

ION Science Ltd offers a take back service. Contact ION Science Ltd for more information.



RECYCLING

This device contains a lithium-ion battery. Dispose of lithium cells immediately. Do not disassemble the battery and do not dispose of it in a fire. Do not mix with the solid waste stream. Spent batteries must be disposed of by a qualified recycler or hazardous materials handler.



WEEE REGULATIONS

Ensure that electrical equipment is disposed of correctly.

Product Overview

The ARA-X4 is a portable multi gas detector.

Getting Started

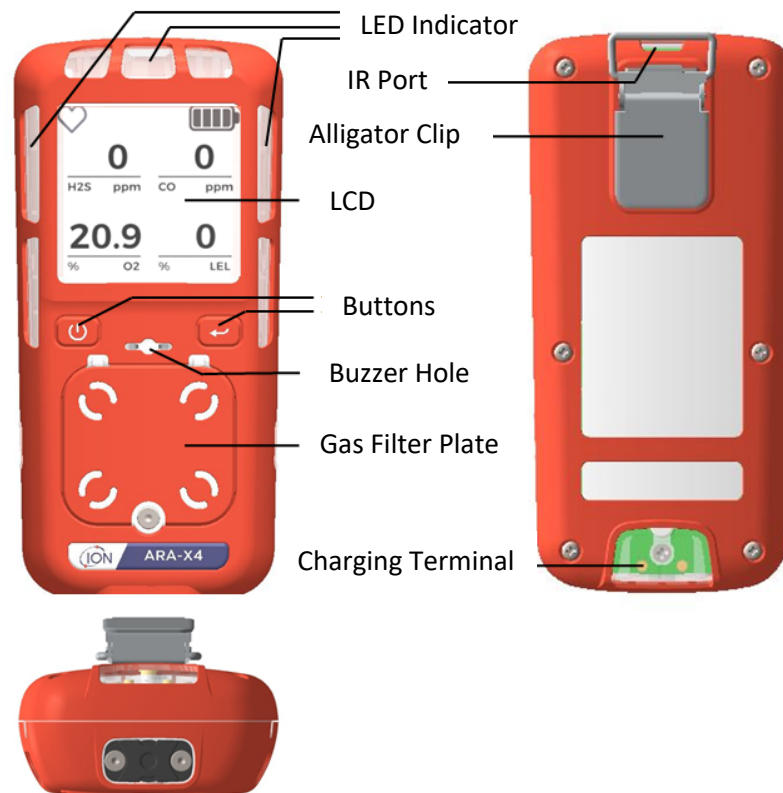

Turning on the ARA-X4

Press and hold the left-hand button for 3 seconds to activate the ARA-X4. The ARA-X4 emits a starting sound and starts sensor warm up. A progress bar indicates warm up progress.



Ensure the ARA-X4 is fully charged prior to the first use.

Please note that the ARA-X4 batteries are shipped with 30% battery charge to adhere to IATA shipping regulations relating to the shipment of li-ion batteries. Refer to [Charging the battery](#).

ARA-X4 requires a 1-minute warm-up time prior to use.

Self-test

After activation and warm up, ARA-X4 performs a self-test.

The self-test has these steps:

- Light the green LEDs for 1 sec.
- Light the red LEDs for 1 sec.

- Light the Health LED for 1 sec.
- Light the green backlight for 1 sec.
- Light the red backlight for 1 sec.
- Operate the buzzer for 1 sec.
- Operate the vibrator for 1 sec.
- Perform sensor test.
- Perform auto-zero (if configured to do so).

You must check that each step of the self-test is working correctly.

After the self-test is completed, auto-zero, bump test or calibration will start if configured to do so.





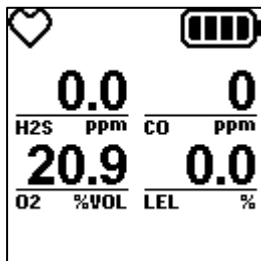

NOTE: Follow any instructions on the LCD display.

Main Display



The displayed sensors may differ depending on the model sensor configuration.

Icons

Name	ICON	Description
Normal running		Health icon blinks at 1 second intervals
Warning		An error or reminder has occurred
Stealth		Stealth mode is active
Logging		ARA-X4 is logging data
Battery		Full (80% to 100% charge)
		60% to 80% charge
		40% to 60% charge

		15% to 40% charge
		Empty (5% 15% charge)
		Charging
Bump		Bump test is overdue
CAL		Calibration is overdue
Peak		Visible if there are peak values

Alarms

When the ARA-X4 detects gases over the alarm threshold, the backlight, buzzer, and LEDs activate. The display alternates every two seconds between the main screen with the alarm type, and the fully expanded screen.

Alarm Type	Display	Description
Low		Backlight red Yellow LED flash (2/sec) Buzzer on (1/sec) Vibrator on (1/sec)
High		Backlight red Red LED flash (4/sec) Buzzer on (2/sec) Vibrator on (2/sec)
TWA (Time Weighted Average)		Backlight red Yellow LED flash (2/sec) Buzzer on (2/sec) Vibrator on (1/sec)

<p>STEL (Short Term Exposure Limit)</p>		<p>Backlight red Red LED flash (2/sec) Buzzer on (2/sec) Vibrator on (1/sec)</p>
<p>OL (Over limit)</p>		<p>Backlight red Red LED flash (4/sec) Buzzer on (2/sec) Vibrator on (2/sec)</p>
<p>Minus OL (Under limit)</p>		<p>Backlight red Red LED flash (4/sec) Buzzer on (2/sec) Vibrator on (2/sec)</p>
<p>Multi</p>		<p>Backlight red Red LED flash (4/sec) Buzzer on (2/sec) Vibrator on (2/sec) All activated alarm types on expanded screen.</p>
<p>More than 2 sensors Alarm active</p>		<p>Backlight red Red LED flash (4/sec) Buzzer on (2/sec) Vibrator on (2/sec) Instead of expanded screen, it displays gas concentrations.</p>

<p>Low Battery (Under 20%)</p>		<p>Beep shortly every 12secs</p>
<p>Critical Battery</p>		<p>Backlight red Red LED flash (4/sec) Buzzer on (2/sec) Vibrator on (2/sec) Turn off within 2 minutes or by holding power button.</p>
<p>Sensor Failure</p>		<p>First 10 sec: Backlight red Red LED flash (2/sec) Buzzer on (2/sec) Vibrator on (1/sec) After 10 sec: Red LED Flash (1/4sec)</p>

Safe Mode

In Safe mode, the SAFE icon replaces sensor readings unless an alarm is triggered. This removes the need for users to assess and interpret the information from the sensor. This may be preferred by some users.



You can configure SAFE mode by connecting to ARA-X Manager via the ARA-X Docking Station or IR Link, or directly via the device menu.

Turning on the Backlight

Press the right-hand button to activate the ARA-X4 LCD backlight.

Turning off the ARA-X4

To turn off the ARA-X4, press and hold the left-hand button. The message *Turn off* is displayed, followed briefly by a 3-2-1 countdown. This is accompanied by vibration and an audible alert. The LCD goes blank when the instrument is off. If you release the button at any point before the LCD goes blank, the device stays on.

Flip Screen

The ARA-X4 has a flip-screen feature, which provides users with the option to change the orientation of the displayed information. The device can be configured via the Device Settings screen or ARA-X Manager software to either:

Auto flip screen:

- This flip screen option is recommended for users who prefer to attach the device to their clothing. With this option, the screen automatically flips if you hold the ARA-X4 at a 135-degree angle for 1 to 2 seconds. The screen goes back to normal if you hold the ARA-X4 vertically.

Always flip screen:

- The screen remains flipped unless the ARA-X4 is reconfigured by the user.

Manual flip screen:

- The left-hand button can be configured via the Device Settings menu, or the ARA-X Docking Station, to manually change the orientation of the display on button press.

Flip screen disabled:

- The flip screen functionality will be switched off. The device will use the standard screen orientation.

Menu Mode

When in Menu mode, ARA-X4 displays an icon-based user interface at the bottom of the LCD.

In Standard Menu Mode, you can access the following options:

- Bump Test
- Device Info

You can also select to access the Admin Menu, which requires a 4-digit password. Refer to the 'Enter Password' section of this manual.

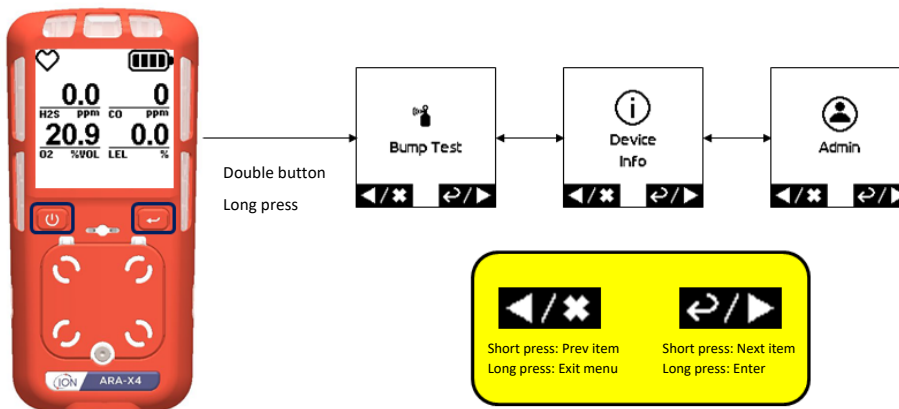

In Admin Menu mode, you configure the device, check its status, or perform maintenance, using these options:

- Bump Test
- Calibration
- Sensor Configuration
- Alarm Settings
- Device Settings
- Language
- Diagnostics
- Device Info
- Logging

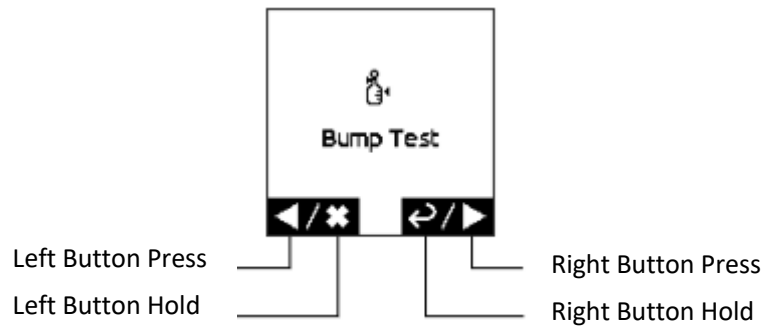

This table describes the icons.

Icon	Description	Icon	Description
	Go to previous item		Go to next item
	Exit		Enter/Select/Change option
	Increase number		Decrease number
	Increase number (at Enter Password screen)		

To activate the left or right icon, press the left-hand or right-hand button once.

To activate the inner left and right icons, press and hold the left-hand button or the right-hand button as appropriate.

Enter Password

When entering Admin Menu mode, a password screen will appear. You must enter the 4-digit password to access Admin Menu mode.



The default password is 0000. We recommend that an authorised person changes the password, via IR Link or Menu mode, before issuing the device to a user.

Press and hold both buttons on the main display to open the Enter Password screen.

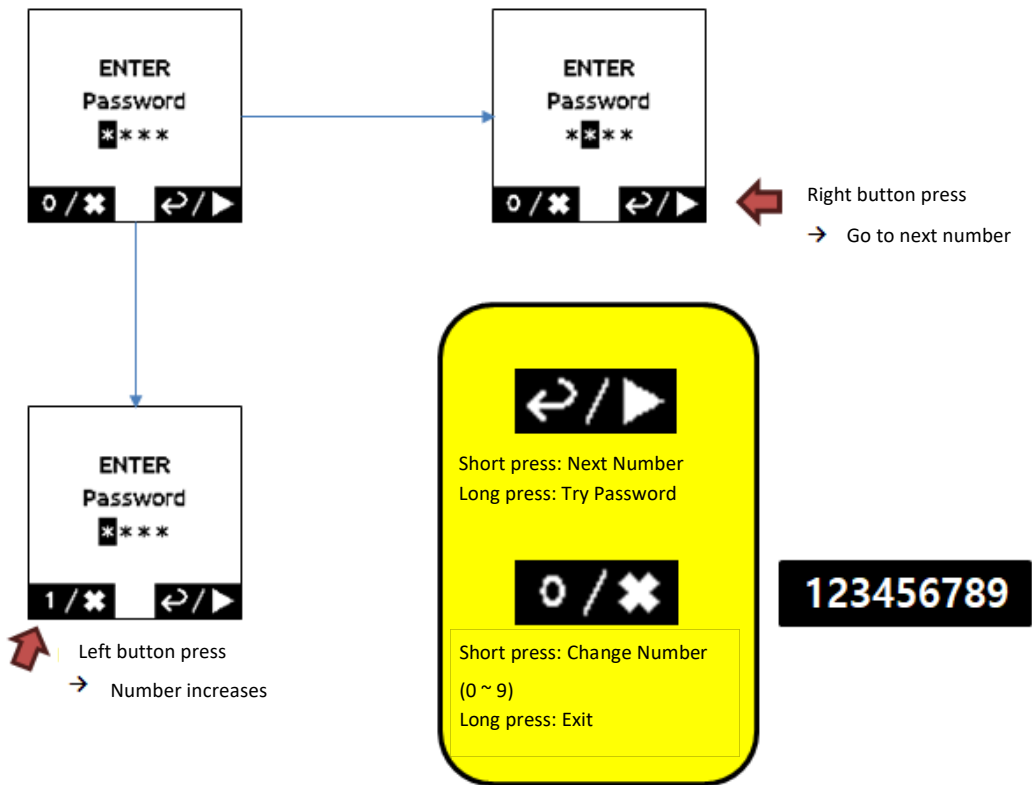

Each time you press the left-hand button, the highlighted number increases by one, from zero to nine and then back to zero. When you have selected the required number, press the right-hand button to move to the next number.

When you have selected all four digits of the password, press and hold the right-hand button to submit the password.

If the password is incorrect, the ARA-X4 beeps five times. The device returns to the Standard Menu mode in which only Bump Test and Device Info can be selected. Enter the correct password to display the full menu.

In Admin mode, all modes provided by the ARA-X4 can be accessed.

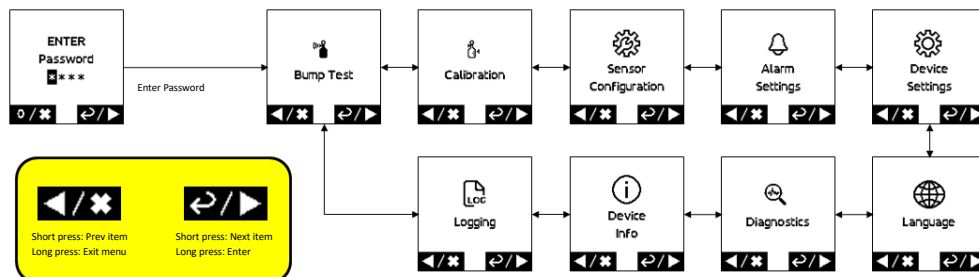

Bump Test Menu

This menu has these options:

- Bump Due
- Bump Test Start

Bump test due shows the number of days until the next bump test is due for each sensor.

If a bump test is due, the health warning (⚠️) icon and the bump test reminder icon (🔊) are displayed on the main screen. The Bump Due screen indicates the sensors for which a bump test is overdue.

To start a bump test, select the option and press and hold the right-hand button.

NOTE: You can run a bump test at any time. We recommend that you run a bump test once a day and after the device suffers possible damage, such as from an impact.

See Performing a Bump Test section for the bump test procedure.

Calibration Menu

This menu has these options

- Calibration Due
- Quick Zero Start
- Manual Calibration Start

Calibration Due shows the number of days until the next calibration is due.

If calibration is due, the health warning (⚠️) icon and the calibration reminder icon (🔧) are displayed, on the main screen, for each sensor.

To start the quick zero process or a calibration, select the required option and press and hold the right-hand button.

See [Calibrating Sensors](#) for the calibration procedure.

Sensor Configuration Menu

When you enter the Configuration menu, choose the sensor to configure. Press the right-hand button to move from sensor to sensor. Press and hold the right-hand button to select the sensor.

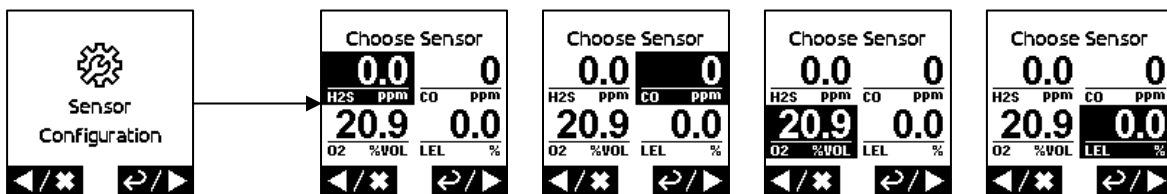

You can configure these options for the sensors:

- Enable/Disable sensor.
- Start-up Zero: Enable/Disable.
- Alarm Mode: Latched/Auto reset.

In Latched mode, the alarm continues after gas concentrations have dropped below high or low alarm. In Auto reset mode, the alarms are reset when the concentrations drop below the alarm limits.

- Measurement Gas (LEL pellistor sensor only).
- LEL Display Unit (LEL sensor only): %LEL/%Vol.
- Next Bump Due.
- Next CAL Due.

Alarm Settings Menu

This menu shows these alarm volume settings.

Low alarm	
High alarm	
TWA alarm	
STEL alarm	

Device Settings Menu

This menu has these options:

- Set date and time
- Display Settings
 - Display Mode:
 - Safe mode
 - Standard mode
 - Backlight Level
 - Dark
 - Bright
 - Flip Screen:
 - Auto
 - Always Flip
 - Disabled
- Left-button quick access – please refer to Quick Access Buttons section below
- Right-button quick access - please refer to Quick Access Buttons section below
- Stealth mode – to disable the audio and visual alarms:
 - On
 - Off
- Confidence type:
 - Disabled
 - LED

- Beep
- LED+Beep

The confidence type gives you an indication that the device is working correctly.

- Change Password

Quick Access Buttons

The left-hand button and the right-hand button have these defaults when you press them:

- Left: Datalog On
- Right: None

You can change these defaults to one of several quick-access options for each button. Press and hold the button in the L-button or R-button **Device Settings** menu and select one of these options:

- Datalog On
- Manual Flip
- Quick Zero
- Bump Test
- Calibration
- Self-test
- None

Language Menu

ARA-X4 supports these languages.

- English
- French
- German
- Dutch
- Spanish
- Italian
- Portuguese
- Chinese

Diagnostics Menu

This menu displays these values and options:

- Current Errors
- TWA Value
- STEL Value
- Reset TWA/STEL?
- Peak Value
- Peak Clear (displayed only if there is a peak value)
- Manual Selftest Start?

Device Info Menu

This menu displays this information about the device:

- Firmware version
- Serial Number
- Model
- User ID

Logging Menu

This menu has these options:

- Current stored data logs
- Clear Datalogs? To delete data logs from the ARA-X4 device.
- Change Logging type:
 - Manual on / off
 - Always on
 - On event
- Datalog interval
- Start Logging? or Stop Logging?, as appropriate.

Performing a Bump Test

Perform a bump test regularly to test sensors and alarms. You can specify a period, in days, after which ARA-X4 counts down to the next due bump test. This does not prevent you running a bump test at any other time, such as when the device suffers an impact. We recommend that you do a bump test once a day.

Before starting Bump test, ensure you are in a clean, normal atmosphere (20.9% v/v O₂) that is free of hazardous gas.

1. Select one of these options:
 - Multi Bump – to test all sensors simultaneously
 - Single Bump – to test sensors separately
2. If you select Single Bump, select the sensor to test.
3. The device will first run through a zeroing sequence. Please ensure that the ARA-X4 is in clean air for this step.
4. Once the zero has completed, connect the calibration cap to the supplied tubing and attach it to the gas plate, then apply gas to the sensors.

During the test, the screen displays sensor readings. We recommend not to interrupt the test, however, it is possible to abort the bump test by following the on-screen instructions.

If the sensor detects sufficient gas (80% of test gas concentration), the bump test is passed. The result of the test is displayed on-screen.

Check the result and hold the right button to go back to main display.

NOTE: The concentration of gas that the device must detect to pass the test can be configured by ARA-X Docking station or IR Link. The default is 80% of test gas concentration.

Zeroing Sensors

If the Auto-zero option is enabled, ARA-X4 starts to zero sensors automatically when you switch it on. You can also start Quick Zero from the Calibration menu. When zeroing sensors, the device must be in a normal atmosphere (20.9% v/v O₂) where there is no hazardous gas.

When zeroing starts, the screen displays current sensor readings.

After several seconds, the results are displayed. If there are no failures, the screen goes back to the main display after 3 seconds.

Calibration Procedure

To maintain sensitivity of the device, we recommend that you calibrate the ARA-X4 regularly. You can specify a period, in days, after which ARA-X4 counts down to the next due calibration. You can perform a manual calibration from Menu mode.

Before starting calibration, you must be in a normal atmosphere (20.9% v/v O₂) where no hazardous gas is present.

1. Select Manual CAL Start and choose one of these calibration options:
 - Multi calibration
 - Single calibration
2. If you choose Single calibration, choose the sensor to calibrate.
3. If you choose Multi calibration, use a multi gas that covers all installed sensors.

The ARA-X4 begins by zeroing the sensor. When Zero Start is displayed, press the right-hand button to start zeroing. The procedure is same as for auto-zero or quick zero. Refer to [Zeroing Sensors](#).

4. If the device passes zeroing, **Apply gas** is displayed on-screen. Connect the calibration cap to the tubing and attach it to the gas plate.

The sensor reading is displayed if ARA-X4 detects gas. Do not interrupt calibration.

5. After a few minutes, the calibration result is displayed. Press and hold the right-hand button to go back to the main display.

We recommend not to interrupt the calibration routine; however, it is possible to abort the calibration by following the on-screen instructions.

Calibration gas concentrations

CO	H ₂ S	O ₂	LEL	HCN	SO ₂
100 ppm	25 ppm	18% v/v	50% (CH ₄ 2.5%)	10 ppm	10 ppm

Logs

The ARA-X4 stores a test log, alarm events, and datalogs. You can use the IR Link to download the logs to ARA-X Manager.

Bump Test Log/Calibration Log

Whenever a bump test or calibration is performed, a bump or calibration log is stored in data memory. The ARA-X4 can save a maximum of 50 bump logs and 50 calibration logs.

Event Log

If an alarm event occurs, the ARA-X4 monitors the peak level and duration. This information is saved as an event log. The ARA-X4 can save a maximum of 50 event logs.

Datalog

The ARA-X4 saves its real-time readings and status in data memory. The datalog frequency (1 to 240 seconds) can be set with the Logging option in the menu, or by connecting to ARA-X Manager via IR Link or ARA-X Docking Station. The ARA-X4 can save a maximum of 60,000 datalogs.

This information is saved in datalogs:

- Time & Date
- Sensor readings
- Alarm status
- Error status
- Temperature
- Battery voltage

Maintenance

Charging the Battery

Connect the supplied 6VDC adapter to the charging terminal located on the bottom side of the device.

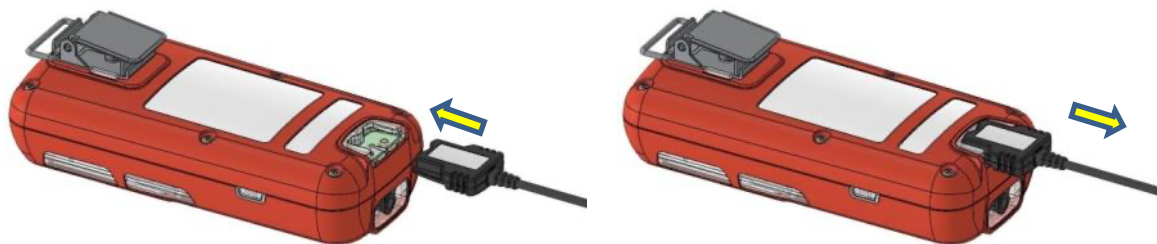

- Charging - Plug the charging connector all the way.
- Remove - Unplug the charging connector to ARA-X4.



Not Charging



Charging and supplying power
– RED charge LED on

- The battery charging requires up to 6 hours from a fully depleted battery.
- The RED LED may remain on after charging for more than 6 hours. This is not a charging problem. It means that ARA-X4 is operating on an external power.



- 1) When removing the charging cable, do not pull on the cable itself, as it may become damaged. Please pull on the charging connector, not the cable.
- 2) Be careful to prevent an electrical short at the contact part of the unused charging cable. When not charging, turn off the power of the 6VDC adapter.

Replacing sensors

NOTE: Use only sensors provided by ION Science Ltd. Users can replace equivalent sensor types only.



Replace sensors only in a non-hazardous environment.

1. Turn off the device.
2. Unscrew the 6 pan head machine screws of the rear case and separate the cases.
3. Unscrew the single countersunk machine screw on the manifold block.

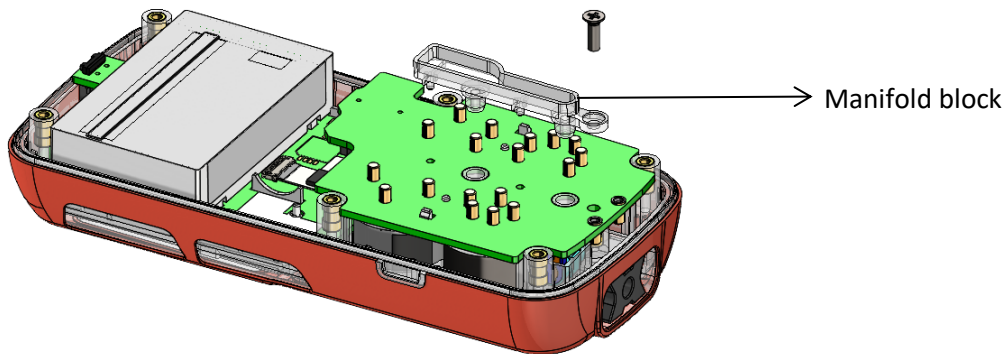

4. Disconnect the sensor PCB from the main PCB.

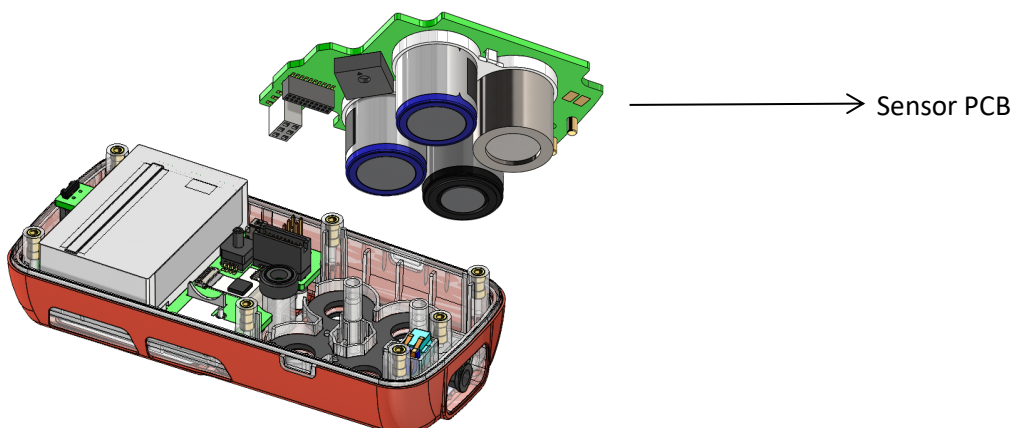

5. Separate the sensor to be replaced from the sensor PCB.

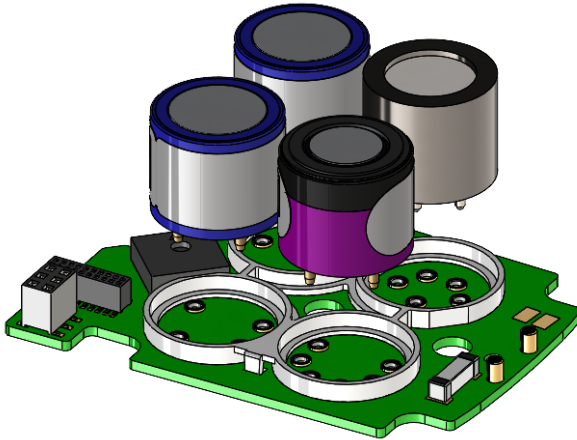

6. Insert the new sensor into the sensor PCB in the correct orientation.
7. Carefully connect the sensor PCB equipped with the new sensor to the main PCB.
8. Install the manifold block with the tube.
9. Reinstall the single countersunk machine screw to the manifold.
10. Fit the rear case.
11. Tighten the rear case with the 6 pan head machine screws.
12. Turn on the instrument.
13. Calibrate the sensor before use. The sensors require a warm-up time after replacement, to stabilise the sensors before calibration. The device should be left running for 1 hour (CO, H₂S, DualTox, HCN, SO₂, LEL) or 8 hours (O₂ sensors) prior to calibration.



Check the coupling and assembly position of the gas sensor.



Be careful not to damage the parts of the PCB when replacing the gas sensor.

Do not overtighten the captive screw.

The replaced sensor must have a warm-up time to stabilize the sensor

The tightening torque must comply with the following specifications: 6 kgf-cm for the rear case and 4 kgf-cm for the manifold

Orientation of the Toxic1 and O2 Gas Sensors

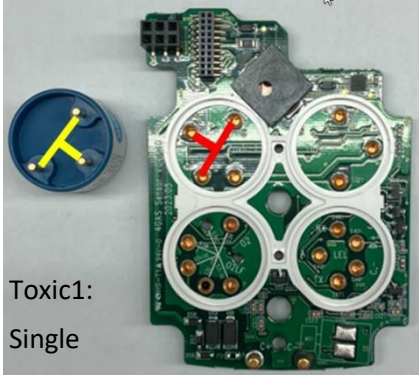
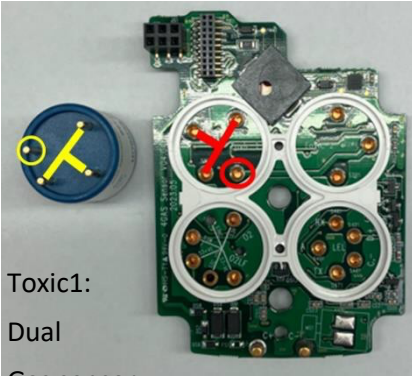
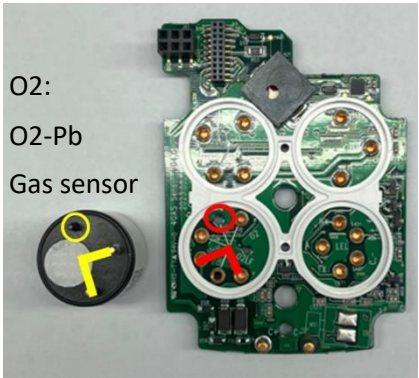
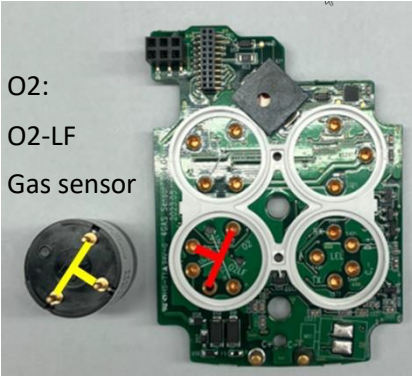
 <p>Toxic1: Single Gas sensor</p>	 <p>Toxic1: Dual Gas sensor</p>	<p>The Toxic 1 sensor can be single or dual, with different pin connections.</p> <p>The dual sensor has a 4-pin connector.</p> <p>Ensure that you orient the sensor correctly when you replace it. In these images, the red and yellow Ts show the correct orientations.</p>
 <p>O2: O2-Pb Gas sensor</p>	 <p>O2: O2-LF Gas sensor</p>	<p>O2 sensors are applicable to both O2-Pb and O2-LF types. Ensure that you orient the sensor correctly when you replace it.</p>

Replacing the Filter

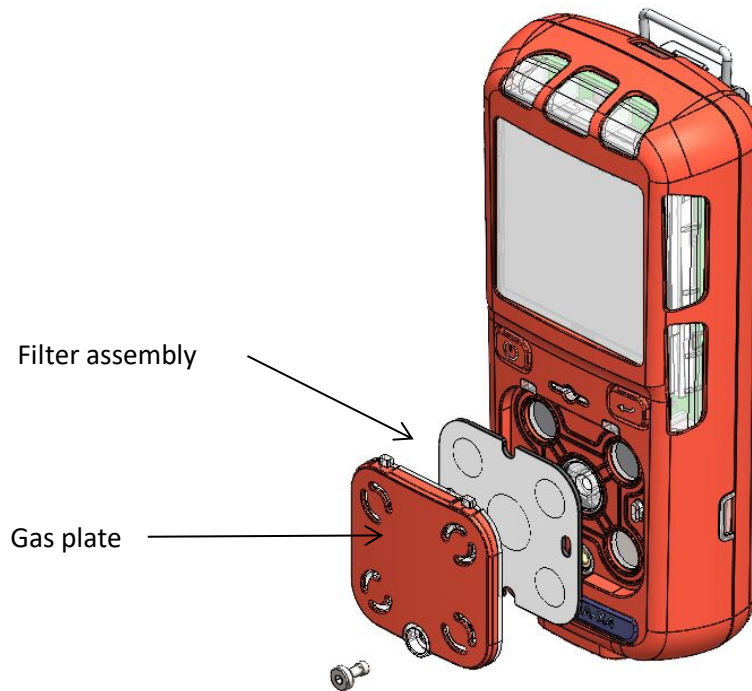

1. Use a 2mm hex wrench, to unscrew the captive cover bolt.
2. Separate the gas plate.
3. Remove the filter assembly.
4. Insert a new filter assembly.
5. Assemble the gas plate.
6. Tighten the cover bolt.



Check that there is no contamination or damage to the filter assembly.
Be careful not to damage the filter when assembling the gas plate.

ARA-X Manager PC Software

The ARA-X Manager application is used to connect to and maintain the ARA X Docking Station and ARA-X4 devices.

The ARA-X Manager enables you to perform maintenance and configuration tasks on the ARA-X4 and docking station, to download data files, and update the firmware of ARA-X4 and ARA-X Docking Station. You can also upgrade the firmware of the docking station remotely using the provided USB memory stick when not directly connected to ARA-X Manager.

You can use these methods to connect the ARA-X4 to the PC on which ARA-X Manager is installed:

- Via the IR Link accessory
A USB cable connects the IR Link accessory to the PC. An infrared connection links the ARA-X4 to the IR Link accessory.
- With the ARA-X Docking Station
You place the ARA-X4 in the docking station, which is connected to the PC by a cable.

You can use the docking station without connecting it to the ARA-X Manager. Refer to the ARA-X Docking Station User Manual.

Download the ARA-X Manager software and latest firmware file from ionscience.com.

Overview

The ARA-X Manager has two top-level tabs: ARA-X Docking Station and ARA-X4. This manual focuses on the ARA-X4 sections of the ARA-X Manager; please refer to the ARA-X Docking Station user manual for more information on ARA-X Docking Station functionality within ARA-X Manager.

The images and tables below describe the layout and purpose of the available fields.

In the tables, all options marked “Read only”, automatically reflect the settings on the connected ARA-X and cannot be updated. Options marked “User (Read only), Admin (Read/Write)” can be updated by an Admin user.

Connecting ARA-X4 to ARA-X Manager

When you first open the ARA-X Manager and ‘read’ your ARA-X4 device to the software, the software will prompt you to create and save a configuration file before you can make any configuration changes to your device. We recommend this is good practice to have a record of the primary configuration settings for your device.

To create a config file, press the ‘ARA-X4 Config Save’ button to save your configuration file to your PC. You can choose your preferred file name and location. You should create a configuration file for each model / sensor configuration that you have, and these should only be applied to the appropriate model.



You must create a configuration file before you can make changes to your ARA-X4. You should create a configuration file for each model you connect to ARA-X Manager.



Ensure that you press ‘Read’ each time you connect an ARA-X4 to the ARA-X Manager before writing settings.

ARA-X4 Device Configuration

In ARA-X Manager, click the ARA-X4 tab. Certain information and options are only available in Admin Mode. Please refer to the table below.

1	Device Information (Read only)	<p>Serial Number: ARA-X4 Serial number</p> <p>Model: ARA-X4 model number</p> <p>FW Version: Firmware version of ARA-X4 device.</p>
2	Device Settings	<p>User ID: Set a User ID to the ARA-X4 A user ID can be used to assign a device to a particular user or site. User (Read only), Admin (Read/Write). The default value of this setting is "Default."</p> <p>Device Language: Select languages - English, German, French, Spanish, Italian, Portuguese, Dutch, and Chinese.</p>

		<p>Password: Input a password for the device to limit access to the Admin menu (Admin Read/Write).</p> <p>Confidence Type: indicates health of the ARA-X4 whilst in use. You can select: Disable, LED, Beep, LED + Beep.</p> <p>Datalog Type: You can select: Manual on/off, Always on, Log on Event.</p> <p>Auto Flip Type: You can configure the LCD orientation: Manual flip, Auto flip, Always flip.</p> <p>Left button option: You can configure the quick access function, accessible by pressing the left button: None, Datalog start, Manual flip quick, Quick zero.</p> <p>Data Log Interval: Set the data log frequency.</p> <p>Confidence Interval: Set confidence alert interval.</p> <p>Backlight: Set the backlight to bright or dark</p> <p>Admin Mode: Admin mode is unlocked on the ARA-X4 so no password input is required to access the menu. Admin (Read/Write).</p> <p>Alarm Latching: When configured to latch the alarm, the audible, vibration and buzzer alarms remain on even if the gas level returns to normal, until you press the reset button.</p> <p>Safe Mode: Hides the gas readings from the display, but triggers the audible and visual alarms when hazardous gas is present</p> <p>Stealth Mode: Disables the use of buzzer and LED.</p> <p>Alarm Latching: When selected, the user must acknowledge the alarm message on screen to reset the alarms</p> <p>Date Format: Set the date format.</p> <p>Hour Format: Set the time format</p> <p>Bump Interval: Set the frequency between bump test reminders</p> <p>Next Bump Due: The next time the gas detector needs to be bump tested</p> <p>Next Cal Due: The next time the gas detector needs to be calibrated</p> <p>TWA Interval: The time-weighted average interval</p> <p>TWA Method: Select the STEL and TWA values to use, choose from OSHA, NIOSH, EH40, ACGIH.</p> <p>STEL Interval: The gas detector's short-term exposure limit interval.</p> <p>Self-test Interval: The next time the gas detector needs to run a self-test</p> <p>Time & Date: Set the time and date on the ARA-X4 device.</p> <p>Set Time & Date to PC: To synchronise the time & date on your ARA-X4 with the PC software, tick the checkbox next to this option and press the smaller 'write' button next to the time & date. Then, when you have updated any other required setting adjustments, please the 'write' (15) button</p> <p>Bump Pass Limit: Set the Bump Test pass limit between 50 to 90%. Default 50%</p> <p>Max Bump Time: Set the max bump time between 10 to 120 sec. Default is set to 30 sec</p> <p>Cal Interval: The frequency of calibration</p>
3	Lockout state (Admin Mode)	<p>Lockout State: When Self-test, Calibration, and Bump tests each fail 10 times in a row, a lockout state occurs.</p> <p>Number of Self-test Failure: Number of consecutive failed self-tests</p> <p>Number of Calibration Failure: Number of consecutive failed calibrations</p> <p>Number of Bump Test Failure: Number of consecutive failed bump tests</p>
4	Lockout Clear (Admin Mode)	Button to clear current Lock out content.
5	Lockout Read	Button to read current Lock out content.

	(Admin Mode)	
6	Select file (Admin Mode)	Button to load firmware upgrade file from PC.
7	Clear Latching	Button to clear the state in which an alarm occurs and is latching.
8	Reset Peak	Button to reset the recorded peak value of the sensor.
9	Reset TWA/STEL	Button to resets recorded values for STEL/TWA.
10	Upgrade Firmware (Admin Mode)	Button to start Firmware upgrade.
11	ARA-X4 Config Save	Save a configuration, which can be re-loaded onto other ARA-X4 devices
12	ARA-X4 Config Load (Admin Mode)	Load a previously saved configuration file, which can be loaded to ARA-X4
13	Read	Read information from the connected ARA-X4 and display in ARA-X Manager software.
14	Logs Read All	Download all logs (Cal, Bump, Event, Data) from your connected ARA-X4 to the ARA-X Manager software.
15	Write (Admin Mode)	Write settings to you ARA-X4 device

ARA-X4 Sensor Configuration

Toxic1 sensor configuration

The screenshot shows the 'ARA-X Manager Admin V1.1.14' interface. The main window is titled 'ARA-X4' and contains a 'Sensor Configuration' tab. Under the 'Toxic1' sub-tab, the following settings are visible:

- Sensor Installed:** A checked checkbox.
- Use:** A checked checkbox.
- Sensor Type:** H2S (with a dropdown menu showing 'Dual_H2S_primary').
- Sensor Installation Date:** 01/01/2000 (with a date picker).
- Sensor Serial Number:** An empty text field.
- Alarm:**
 - High: (value: 15.0)
 - Low: (value: 10.0)
 - STEL: (value: 15.0)
 - TWA: (value: 10.0)
 - Low Alarm Acknowledge:
- Auto Zero at Start Up:**
- Gas Calibration:**
 - Base Gas: 0.0 ppm
 - Max Gas: 100.0 ppm
 - Span Gas: 25.0 ppm
- Test and Calibration Data Table:**

Last Bump Test Reading	20.1	ppm
Last Bump Test Time	19/11/2025	
Last Cal Reading	24.9	ppm
Last Cal Time	19/11/2025	
Last Selftest Time	26/01/2026	
Decimal Point	1	
Last Cal Error	Calibration OK	

At the bottom of the configuration window, there are three buttons: 'Read', 'Logs Read All', and 'Write'. The left sidebar shows 'Device Connected' with 'COM5[ARA-X4]' selected, and a language dropdown set to 'English'. The ION Science LTD. logo and contact information are visible in the bottom left corner.

Sensor Installed	Tick box checked indicates Toxic1 sensor is installed. User (Read only), Admin (Read/Write).
Use	Tick box checked indicates Toxic1 sensor is activated. You can enable or disable an installed sensor. Disabled sensors are not shown on the ARA-X4 display and do not monitor the associated gas.
Sensor type	The sensor type must be selected when changing the sensor type. User (read only), Admin (read)
Serial Number	The installed sensor serial number should be updated here when replaced. User (Read only), Admin (Read/Write).
High Alarm	When ticked, the High alarm is used. User (Read only), Admin (Read/Write).
Low Alarm	When ticked, the Low alarm is used. User (Read only), Admin (Read/Write).
STEL Alarm	When ticked, the STEL alarm is used. User (Read only), Admin (Read/Write).
TWA Alarm	When ticked, the TWA alarm is used. User (Read only), Admin (Read/Write).



Low Alarm Acknowledge	When ticked, users must acknowledge the low alarm to reset the audio and visual alarms.
Auto Zero at Start Up	When ticked, the ARA-X4 will zero the selected sensor during the start-up sequence.
Span Gas (Admin Mode)	Set the calibration span gas concentration.
Base Gas (Admin Mode)	Base gas concentration used. (Read only).
Max Gas (Admin Mode)	Max gas concentration. (Read only).
Last Bump test Reading (Admin Mode)	The value read from the last Bump test. (Read only).
Last Bump test Time (Admin Mode)	Date of the last bump test. (Read only).
Last Cal Reading (Admin Mode)	The value read from the last calibration. (Read only).
Last Cal Time (Admin Mode)	Date of the last calibration. (Read only).
Last Self-test Time (Admin Mode)	Date of the last self-test Time. (Read only).
Decimal Point (Admin Mode)	Decimal Point available for the sensor. (Read only).
Last Cal Error (Admin Mode)	Last calibration error or successful calibration. (Read only).

Toxic2 sensor configuration

ARA-X Manager Admin V1.1.14

ARA-X Docking Station | ARA-X4 | Logs | SW Configuration | Admin

Device Configuration | Sensor Configuration

Toxic1 | Toxic2 | O2 | LEL

Sensor Installed Sensor Type: CO Dual_CO_primary

Use Sensor Installation Date: 01/01/2000

Sensor Serial Number: _____

Alarm

High Low STEL TWA

200.0 35.0 50.0 35.0

Low Alarm Acknowledge

Auto Zero at Start Up

Base Gas: 0.0 ppm
 Max Gas: 500.0 ppm
 Span Gas: 100.0 ppm

Last Bump Test Reading: 80 ppm
 Last Bump Test Time: 19/11/2025
 Last Cal Reading: 99 ppm
 Last Cal Time: 19/11/2025
 Last Selftest Time: 26/01/2026
 Decimal Point: 0
 Last Cal Error: Calibration OK

Read Logs Read All Write

Language: English

ION Science LTD.
 The Hive, Butts Lane, Fowlmere
 Royston, SG8 7SL, UK
 Tel: +44 (0) 1763 208 503
 info@ionscience.com

Refer to [Toxic1 Sensor Configuration](#)

O2 Sensor Configuration

The screenshot shows the 'ARA-X Manager Admin V1.1.14' interface. The main window is titled 'ARA-X4' and contains tabs for 'Device Configuration' and 'Sensor Configuration'. The 'Sensor Configuration' tab is active, showing settings for the 'O2' sensor. The interface includes a left-hand navigation pane with 'Device Connected' options (COM, LAN, USBMemory) and a 'Language' dropdown set to 'English'. The main configuration area has the following sections:

- Sensor Settings:**
 - Sensor Installed** (Sensor Type: O2 Lead Free, O2_LF_primary)
 - Use** (Sensor Installation Date: 01/01/2000)
 - Sensor Serial Number: [Empty field]
- Alarm Settings:**
 - High** (23.5) and **Low** (19.5)
 - Low Alarm Acknowledge
 - Auto Zero at Start Up**
- Gas Calibration:**
 - Base Gas: 20.9 %Vol
 - Max Gas: 25.0 %Vol
 - Span Gas: 18.0 %Vol
- Test and Calibration History:**
 - Last Bump Test Reading: 18.5 %Vol
 - Last Bump Test Time: 19/11/2025
 - Last Cal Reading: 18.0 %Vol
 - Last Cal Time: 19/11/2025
 - Last Selftest Time: 26/01/2026
 - Decimal Point: 1
 - Last Cal Error: Calibration OK

At the bottom of the window, there are three buttons: 'Read', 'Logs Read All', and 'Write'.

Refer to [Toxic1 Sensor Configuration](#)

LEL Sensor Configuration

The screenshot shows the 'Sensor Configuration' window for the LEL sensor. Key settings include:

- Sensor Installed:** Checked. Sensor Type: Pellistor, LEL_CAT_primary.
- Use:** Unchecked. Sensor Installation Date: 01/01/2000.
- Alarm:** High and Low alarms are checked. High alarm level is 20.0, Low alarm level is 10.0.
- Calibration Gas:** Methane.
- LEL Unit:** %LEL.
- Gas Readings:** Base Gas: 0.0 %LEL, Max Gas: 100.0 %LEL, Span Gas: 2.0 %LEL.
- Test Results Table:**

Last Bump Test Reading	40.0	%LEL
Last Bump Test Time	15/09/2025	
Last Cal Reading	50.0	%LEL
Last Cal Time	15/09/2025	
Last Selftest Time	15/09/2025	
Decimal Point	1	
Last Cal Error	Calibration OK	

Refer to [Toxic1 Sensor Configuration](#), plus:

Calibration Gas (Admin Mode)	CH4 - Methane, H2 - Hydrogen C2H4 - Ethylene C2H6 - Ethane C3H8 - Propane C4H10 - Butane C5H12 - Pentane C6H14 - Hexane
LEL Unit (Admin Mode)	%LEL or %VOL

Creating a Device Configuration File

It is possible to create a default configuration file which can be easily applied to different devices. The configuration settings that can be adjusted include:

- Alarm settings
- STEL / TWA method
- Bump & Calibration intervals
- ARA-X4 device configuration preferences, such as language, datalogging type, quick access buttons
- ARA-X Docking Station preferences, such as automatic features, bump and calibration limits

There are three ways to create a configuration file:

1. **ARA-X4 config only:** Connect an ARA-X4 via ARA-X Docking Station or IR Link, make adjustments to the ARA-X4 configuration and save this for future use.
2. **ARA-X Docking Station config only:** Connect an ARA-X Docking Station, make adjustments to the ARA-X Docking Station configuration and save this for future use.
3. **ARA-X4 or ARA-X Docking Station config file:** Configure the settings within ARA-X Manager without an ARA-X4 or ARA-X Docking Station connected and save this file for future use.

ARA-X4 Configuration file:

Open the ARA-X Manager and navigate to the ARA-X4 tab. Make the desired changes to the Device Configuration. Press the 'ARA-X4 Config Save' button and choose the location and name for your configuration file.

ARA-X Docking Station Configuration file:

Open the ARA-X Manager and navigate to the ARA-X Docking Station tab. Make the desired changes to the Dock Configuration. Press the 'Save' button and choose the location and name for your configuration file.



A configuration file must be created for each model type. Only configuration files for matching sensor configurations should be used. Please check this before applying to ARA-X4.

Loading a saved Configuration File

ARA-X4 Configuration file:

There are two options for sending a saved configuration file to your ARA-X4:

1. Send to an ARA-X4 which is connected to ARA-X Manager by ARA-X Docking Station or IR Link.

- Install the default configuration file within your ARA-X Docking Station, which can be applied to every compatible ARA-X4 that is connected to your ARA-X Docking Station.

ARA-X4 Configuration file:

Open the ARA-X Manager and navigate to the ARA-X4 tab. Press the 'ARA-X4 Config Load' button to select your previously saved configuration file from your computer. Once selected, press 'Write' to send the file to your ARA-X4.

NOTE: to successfully apply a configuration file, the ARA-X4 must have the same sensors installed to match the saved configuration. If the sensors do not match, an error message will appear, and the configuration will not be applied to the device.

To load an ARA-X4 configuration file onto your ARA-X Docking Station, please refer to the ARA-X Docking Station user manual.

Logs

The screenshot shows the 'ARA-X Manager Admin V1.1.14' interface. The 'Logs' tab is active, displaying a table of log sessions and various control buttons. Red boxes with numbers 1 through 10 highlight specific elements:

- 1:** Serial Number field (BB25140006)
- 2:** Session table
- 3:** Logs Read All button
- 4:** Log From Local Disk button
- 5:** Datalog Stop button
- 6:** Datalog Start button
- 7:** Log Read button
- 8:** Log Select and Read section (Datalog selected)
- 9:** Conversion section (Excel selected)
- 10:** Delete button

Session	File Name	Button	Se
1	BumpLog_BB25140006_12092025_150701.dat	View	(
2	BumpLog_BB25140006_15092025_100603.dat	View	(
3	BumpLog_BB25140006_15092025_104551.dat	View	(
4	CalLog_BB25140006_08092025_102318.dat	View	(
5	CalLog_BB25140006_15092025_092604.dat	View	(
6	CalLog_BB25140006_15092025_103650.dat	View	(
7	CalLog_BB25140006_19112025_122910.dat	View	(
8	DataLog_BB25140006_12092025_121635.dat	View	(
9	DataLog_BB25140006_12092025_122546.dat	View	(
10	DataLog_BB25140006_12092025_133616.dat	View	(
11	DataLog_BB25140006_12092025_141417.dat	View	(
12	DataLog_BB25140006_15092025_094928.dat	View	(
13	DataLog_BB25140006_15092025_101625.dat	View	(

1	Log summary	The logs are shown by serial number of connected ARA-X4 device, and user ID
2	Session	Displays the downloaded log files that are available on the ARA-X4 device. Logs are shown by log type (bump log, cal log, data log, event log), serial number, date and session number. Use the 'Excel' and 'ARA-X Manager View' buttons (4) to choose whether you want to view the logs in ARA-X Manager, or export to Excel. Then, press the 'View' button to open the logs in the desired format. Data logs are stored in the following location, as default: C:\ION Science LTD\Ara-X Manager\ION Science\ARAX\Log
3	Log Read All	To read all logs from the ARA-X4 device at once
4	Log from local disk	To open previously downloaded log files via the ARA-X Manager
5	Stop data log	To stop data logging on the connected ARA-X4 device
6	Start data log	To start data logging on the connected ARA-X4 device
7	Log Read	To download only a specific type of log file, use the radio buttons to select the log type of interest and then press the 'Log read' button. Log type options are: Event Log, Bump Log, Cal Log, Data Log
8	Clear ARA-X4 logs	Clears the logs from the ARA-X4 device memory
9	Log view / log conversion	Use the radio button to choose whether you want to view the logs in ARA-X Manager, or export to Excel. Then, press the 'View' button to open the logs in the desired format.
10	Delete	To delete the selected log from ARA-X Manager. First, highlight the log that you wish to delete, then press the 'delete' button.

SW Configuration

The ARA-X Docking Station can be configured to work on a local network. You can connect to ARA-X Manager via the LAN connection setting and configure your Ethernet settings via this page when logged into ARA-X Manager Admin Mode:

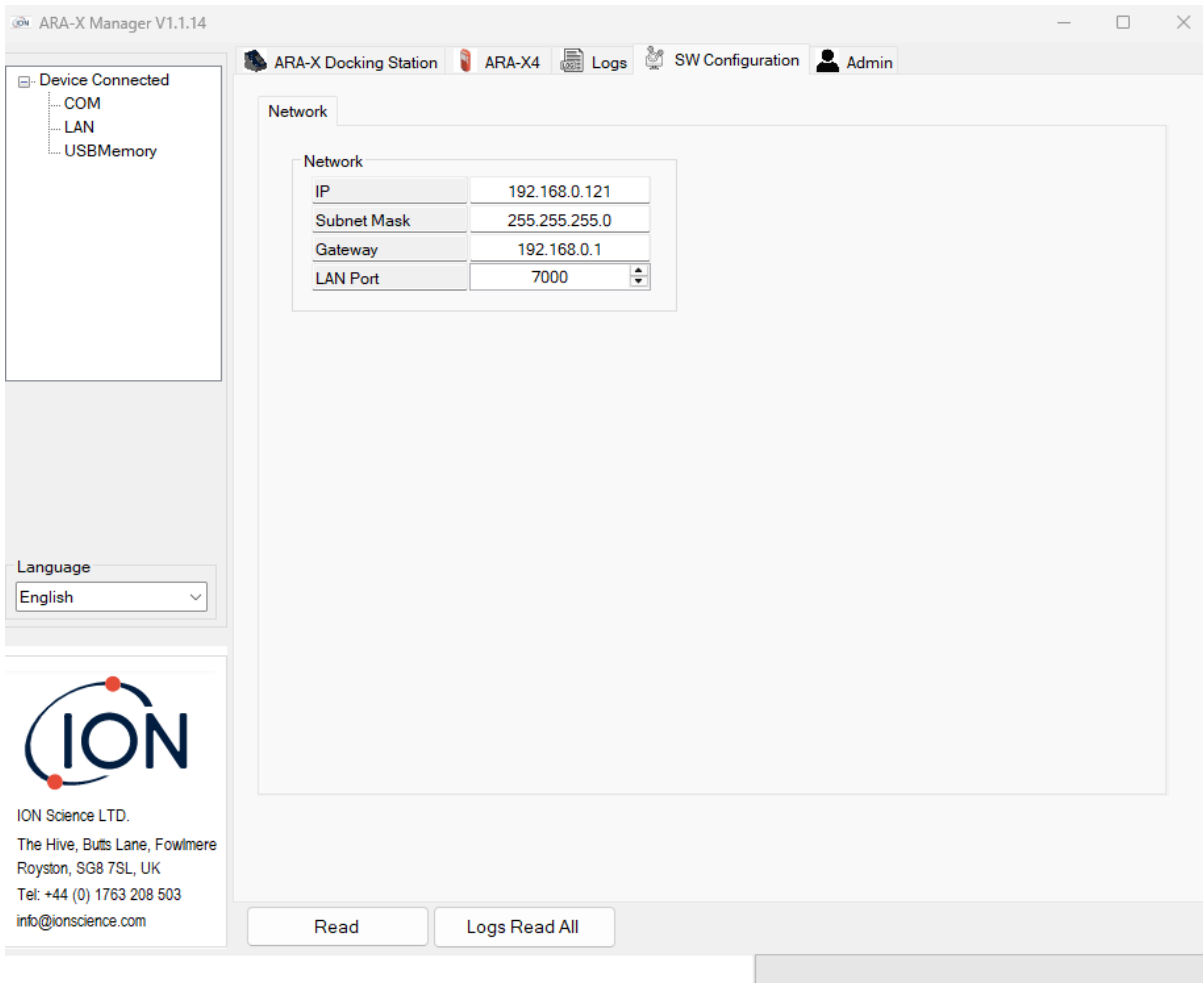

The screenshot shows the ARA-X Manager V1.1.14 software interface. The window title is "ARA-X Manager V1.1.14". The top navigation bar includes "ARA-X Docking Station", "ARA-X4", "Logs", "SW Configuration", and "Admin". On the left sidebar, there is a "Device Connected" section with options for "COM", "LAN", and "USBMemory". Below this is a "Language" dropdown menu set to "English". At the bottom left of the sidebar is the ION logo and contact information for ION Science LTD. The main content area is titled "Network" and contains a table with the following configuration:

Network	
IP	192.168.0.121
Subnet Mask	255.255.255.0
Gateway	192.168.0.1
LAN Port	7000

At the bottom of the main area, there are two buttons: "Read" and "Logs Read All".

Admin Login

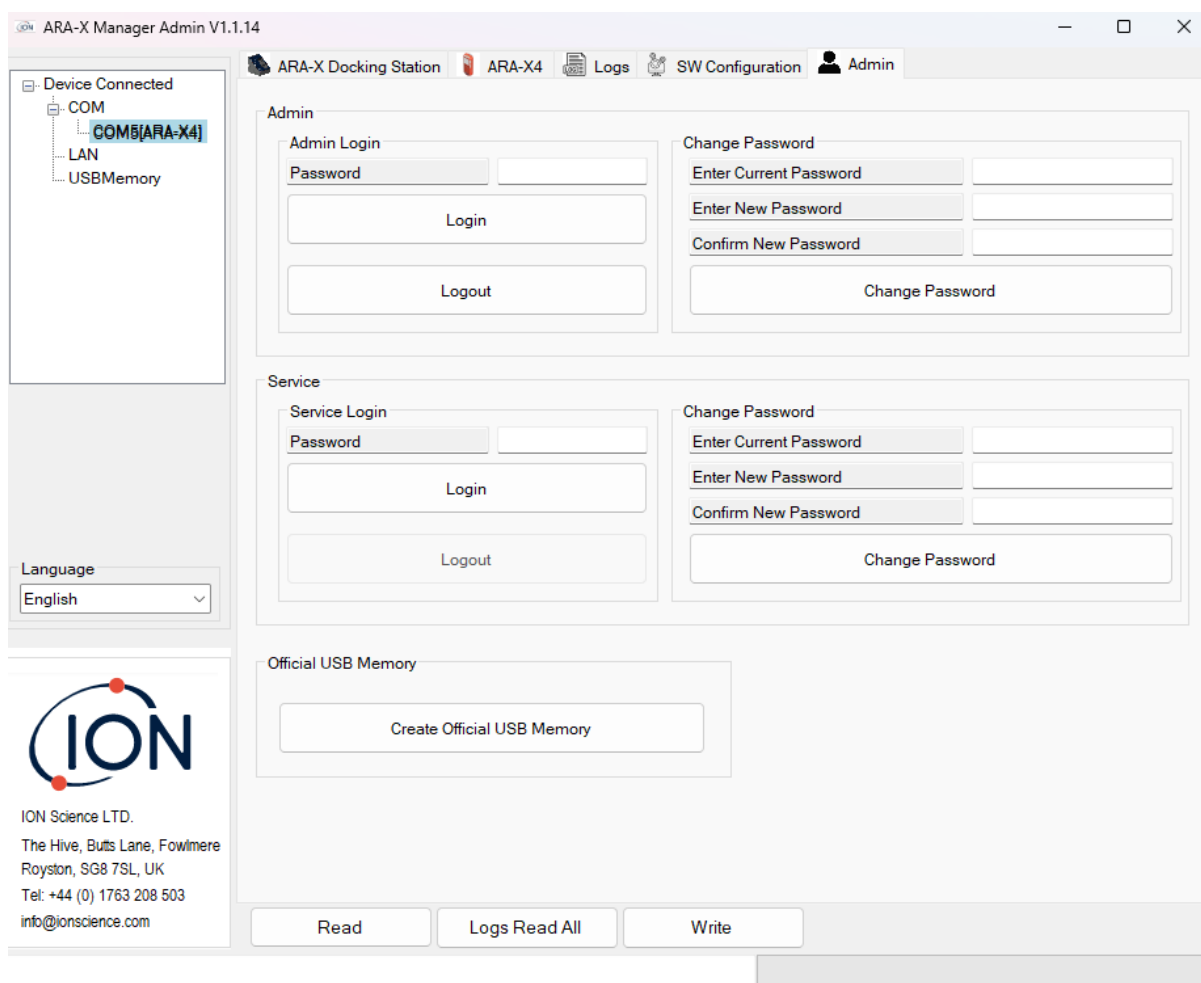

Admin Login: Enter your password and log in to use ARA-X Manager in administrator mode. The initial password is "2025".

Admin Logout: Press this option to revert ARA-X Manager to standard User Mode.

Change Password: An Admin user can change passwords by entering a current password and a new password.

Service Password: For use by ION Science service trained personnel only.

Create Official USB Memory: To generate an encryption key code to configure your USB memory for use with the ARA-X Docking Station.

Creating an encrypted USB

To transfer data between ARA-X Docking Station and ARA-X Manager it is necessary to use an encrypted USB. The ARA-X Docking Station is supplied with an encrypted USB, however, it is possible to encrypt a standard USB to be used with the ARA-X Manager and ARA-X Docking Station.

To create an encrypted USB, this can be done in Admin mode of ARA-X Manager:

1. Insert your USB into your PC
2. Open ARA-X Manager and select the 'USB Memory' option from the 'Device Connected' option.
3. Press 'Read'
4. Navigate to the Admin tab and enter your Admin password. The 'Create Official USB Memory' option should now appear.
5. Press 'write'

You can now transfer data between ARA-X Manager and your ARA-X Docking Station.

To transfer data to the encrypted USB, this must be done via the ARA-X Manager. To do so, load the desired settings or configuration settings into ARA-X Manager and press the 'write' button, whilst the encrypted USB is connected.



The ARA-X Docking Station will not accept files that have been manually transferred onto the USB from the PC, and these must be uploaded to the USB via the ARA-X Manager.

Technical Specification

Appearance	Size (excl. belt clip)	67 x 140 x 34 mm
	Weight	<300g
	Button	2-Button Operation
Environment	Operating temperature	-20°C to 55°C (-4°F to 131°F)
	Humidity	5 ~ 95% RH
	IP	IP67
Display	Display	Liquid Crystal Display: 45 x 45 mm, Internal backlight (red and green), FSTN, COG, 128x128 Graphic LCD, FPC
Alarm	Alarm conditions	Low, High, TWA, STEL, OL, -OL, Multi alarm
	Visual alarm	6 Red/Green LED, plus 1 Green LED (confidence)
	Audible alarm	PIEZO Buzzer, 95dB @ 30cm
	Vibrating alarm	Vibrator (temperatures greater than -10°C)
Battery	Characteristics	Li-ion Battery, DC 3.7V, 2000mAh
	Typical run time	18 hours for 4Gas-LEL Pellistor model 60 days for 4Gas-LEL IR model*
	Charging time	6 hours to full charge (from fully depleted battery)
Gas Sensor	Types	Electro Chemical: CO, H ₂ S, O ₂ , SO ₂ , HCN Pellistor: LEL (CH ₄) NDIR: LEL (CH ₄)
	Detection Range	CO: 0 to 500ppm H ₂ S: 0 to 100ppm O ₂ : 0 to 25% SO ₂ : 0 to 20 ppm HCN: 0 to 30 ppm LEL: 0 to 100%LEL
	T90 response time	O ₂ (L): <15 sec O ₂ (LF): <20 sec CO: <30 sec H ₂ S: <30 sec DualTox CO: <40 sec DualTox H ₂ S: <30 sec LEL (CAT): <30 sec LEL (IR): <45 sec HCN: <75 sec SO ₂ : <60 sec
Data Log	Storage	Up to 50 bump log, 50 calibration log, 50 event log and 60,000 data logs.

*Based on 11 hours use per day

Detailed Gas Sensor Information

Gas Type / Detection Range	Sensor type	Sensor P/N
CO 0 ~ 500ppm	Single gas	926220
H2S 0 ~ 100ppm	Single gas	926221
CO/H2S Dual	Dual-Tox	926222
O2 0 ~ 25%	Leaded	926223
	Lead free	926224
LEL 0 ~ 100 %LEL	Pellistor	926225
	NDIR	926226
SO2 0 ~ 20ppm	Single gas	926227
HCN 0 ~ 50ppm	Single gas	926228

Default Alarm Levels

Gas	CO (ppm)	H2S (ppm)	O2 (%)	LEL (%)	SO2 (ppm)	HCN (ppm)
High	200	15	23.5	20	5	10
Low	35	10	19.5	10	10	4.7

Risks, warnings and guidance when using LEL sensors

Workplace exposure limits (WELs) apply to numerous compounds which can form explosive atmospheres. Local Legislative limits should be adhered to at all times.

Sensors offer stable during operation within their operational temperature range but are susceptible to poor performance due to temperature shocks.

There are certain environments that ARA-X4 or LEL sensors might be used in that could impact their use or performance.

The following factors are identified to have a harmful effect on catalytic elements as used in the gas sensor part number 926225.

Poisoning: some compounds will decompose on the catalyst and form a solid barrier over the catalyst surface. This action is cumulative, and prolonged exposure will result in an irreversible decrease in sensitivity. Common of these substances include but are not limited to: lead or sulphur containing compounds, silicones, phosphates, and HMDS (hexamethyldisilazane).

Inhibition: certain other compounds, especially hydrogen sulphide and halogenated hydrocarbons, are absorbed or form compounds that are absorbed by the catalyst. The resultant loss of sensitivity is temporary and in most cases a sensor will recover after a period of operation in clean air. If the presence of poisoning or inhibition is suspected, adequate protective action for the sensor should be taken.

Routine operation of the sensor in environments containing such compounds should be avoided or mitigated against.

Dusty environments can negatively impact sensor performance. Use of sensors outside of recommended operating temperature, humidity and pressure environments can result in inaccurate readings.

LEL sensor limitations

Infrared (IR) LEL sensors can detect methane and other flammable gases. Typically, these types of sensors have some cross-sensitivities to compounds including methylene, ethylene, ethane, short-chain alkanes and ethanol. Please note this is not an exhaustive list. IR sensors are not sensitive to hydrogen will not detect this.

Catalytic LEL sensors detect methane and other flammable gases. These types of sensors are cross-sensitive to compounds including ammonia, benzene, hydrocarbons, alcohols, and hydrogen. Please note this is not an exhaustive list.

Troubleshooting

This table lists problems that you may encounter, and possible solutions. If you cannot resolve a problem, contact your local service centre or distributor, or return the device for service. The device may have to be dismantled.

Problem	Solution
ARA-X4 does not activate	Press and hold the left-hand  power button for at least two seconds. If the device does not power on: Charge the battery: Connect the 6Vdc adapter. Check that the red charging LED is lit. Charge for at least thirty minutes and then turn on the device. If the charging LED does not light or if the device does not charge, the battery or a fuse might be damaged. Please contact your local service centre.
LCD or backlight does not turn on	Turn the device off and on. Check that the LCD is displayed during the self-test. If problems persist, please contact your local service centre.
Alarm LEDs do not turn on	Turn the device off and on. Check that the LEDs turn on during the self-test. If problems persist, please contact your local service centre.
Alarm buzzer is weak, or buzzer does not work	Turn the device off and on. Check for the buzzer sound during the self-test. Ensure that the buzzer hole is not blocked. If problems persist, please contact your local service centre.
Alarm vibration is weak, or vibrator does not work	Turn the device off and on. Check for vibration during the self-test. If problems persist, please contact your local service centre.
Unable to communicate with the ARA-X Manager via the IR Link / IR settings are not enabled	Clean the IR windows on your ARA-X4 and IR Link. With no other electronic devices nearby, place the ARA-X4 and the IR Link face to face, 5cm to 7cm apart. Attempt communication. Cover the space near the ARA-X4 and IR Link with paper or cloth to block ambient light. Do

	not block the communication path between devices. If problems persist, please contact your local service centre.
Gas sensor has failed	Use IR Link to check the model name and the gas sensor configuration. Check the model name ordering for sensor configuration. If the model number and sensor configuration are correct, turn the device off and on. Check the sensor during the self-test. If problems persist, please contact your local service centre.
LEL sensor has failed	Check the gas sensor configuration. Turn the device off and on. Check the self-test result. The LEL sensor may require replacement. If problems persist, please contact your local service centre.
LCD Flip does not work	Change the Flip screen settings and check the display. Turn the device off and on. If problems persist, please contact your local service centre.
Bump test fails	Re-calibrate the sensor. If problems persist, please contact your local service centre.
Calibration fails	Re-calibrate the sensor. If calibration continues to fail, replace the sensor. If problems persist, please contact your local service centre.

Accessories

Manual Aspirator Pump with Sample Probe – part number 926253

The Manual Aspirator Pump with Sample Probe is an accessory intended for use with the ARA-X4 Gas Detector to draw a representative atmospheric sample from a remote location such as a confined space. This document provides basic assembly instructions and operation guidelines.

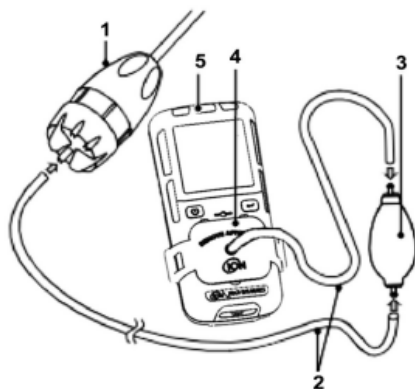

Item	Description
1	Sample probe
2	Tubing
3	Aspirator bulb
4	Test cap
5	ARA-X4

Important Safety Information – Read First

The detector is a personal safety device. It is your responsibility to respond appropriately to the alarm. To avoid personal injury and/or property damage, please read and adhere to the following cautions. Ensure the ARA-X4 has sufficient battery charge to operate before sampling. Ensure a bump test / calibration has taken place prior to using the detector.

Warnings

- When sampling with the ARA-X4 the calibration cap and aspirator bulb must be used with the sample probe.
- To measure hazardous gas in the atmosphere from a remote location, such as in a confined space, the sample probe must be connected to the diffusion model calibration cap using the Teflon-lined tubing.
- Squeeze the aspirator bulb once for each foot of tubing. Continue squeezing the aspirator bulb for a minimum of 60 seconds and until the reading stabilizes.
- Follow all safety procedures as defined by your employer.
- Perform a leak test to ensure there are no leaks in the tubing, connections or mechanism.
- Ensure all connections are secure before sampling.
- When sampling, the calibration cap and aspirator bulb must be used with the sample probe.
- Caution: To prevent the Teflon lining inside the tubing from causing blockage when connecting it to the sample probe, the open end of the tubing must be flared.

How to use the Manual Aspirator Pump with Sample Probe:

1. Connect the bulb, sample probe, tubing and test cap. Do not attach the test cap to the detector.
2. Activate the detector. Wait until the startup sequence is complete.
3. Attach the test cap to the detector.
4. Perform a leak test. Cover the open inlet of the tubing or probe with your finger. Squeeze the bulb, then release it. If there are no leaks in the system, the bulb remains deflated until you remove your finger from the open end of the tubing or probe.
5. Insert the sample probe into the remote location to be sampled.
6. Squeeze the aspirator bulb once for each foot of tubing. Continue squeezing the aspirator bulb for a minimum of 60 seconds and until the reading stabilizes.
7. Follow all safety procedures as defined by your employer.

Limited Warranty

ION Science Ltd warrants the product to be free from defects in material and workmanship under normal use and service for a period of five years, beginning on the date of shipment to the buyer. This warranty extends only to the sale of new and unused products to the original buyer.

This warranty does not include:

- Any damage or defects attributable to repair of the product by any person other than by an authorised service centre, or the installation of unapproved parts on the product; or
- Any product which in ION Science Ltd's opinion, has been misused, altered, neglected or damaged, by accident or abnormal conditions of operation, handling or use.

The obligations set forth in this warranty are conditional on:

- Proper storage, installation, calibration, use, maintenance and compliance with the product manual instructions and any other applicable recommendations of ION Science Ltd;
- The buyer promptly notifying ION Science Ltd of any defect and, if required, promptly making the product available for correction. No goods shall be returned to ION Science Ltd, until receipt by the buyer of shipping instructions from ION Science Ltd; and
- The right of ION Science Ltd to require that the buyer provide proof of purchase such as the original invoice, bill of sale or packing slip to establish that the product is within the warranty period.

Please refer to the ION Science ARA-X4 warranty statement for full details.

Certifications / Approvals

ATEX

Ex ia op is IIC T4 Ga or Ex da ia IIC T4 Ga
Certificate number: KSCP 24ATEX0024X

IECEX

Ex ia op is IIC T4 Ga or Ex da ia IIC T4 Ga
IECEX KSCP 24.0047X

Ex ia op is IIC T4 Ga or Ex da ia IIC T4 Ga
KSCP 24ATEX0024X
IECEX KSCP 24.0047X

North America

CL. I Div 1 Groups A, B, C, D, T4; CL. I ZN 0. AEx ia op is IIC T4 Ga or CL. I ZN 0. AEx da ia IIC T4 Ga
Certificate number: ETL25CA106109393
Ambient Temperature: $-20^{\circ}\text{C} \leq T_a \leq +55^{\circ}\text{C}$

North American flammable gas performance testing:

ION Science ARA-X4 has been successfully tested for ISA 60079-29-1. Both the ION Science ARA-X4 catalytic bead flammable sensor and IR sensor were evaluated for ISA 60079-29-1.

The evaluation is valid only with the pumping flow rate 500 ml/min, 1 m length tube and CH₄ (Methane) gas. The other options are not the scope of ISA 60079-29-1.

For the compliance of ISA 60079-29-1, the adjustable alarm set point shall be 10% relative below the concentration of the standard test gas, or as near as possible to that concentration.

ION Science ARA-X4 was pressure tested for 80, 100 and 120 kPa in ISA 60079-29-1. Pressures outside of 80 - 120 kPa are NOT the scope of ISA 60079-29-1.

Risks of working in methane environments

Methane is flammable, can form explosive mixtures with air and can displace oxygen, causing rapid suffocation. It is colourless and odourless, and vapours are lighter than air, therefore, it can be difficult to detect without suitable sensing equipment, such as LEL sensors. Sensors must be intrinsically safe for operation in potentially explosive atmospheres.

ION Science Contact Details

ION Science Ltd – UK/Head Office

Tel : +44 (0) 1763 208 503

Web: www.ionscience.com | Email: info@ionscience.com

ISM ION Science Messtechnik – Germany Office

Tel: +49 (0) 2104 1448-0

Web: <https://www.ism-d.de/en/> | Email: sales@ism-d.de

ION Science India – India Office

Tel: +91 4048536129

Web: www.ionscience.com/in | Email: kschari@ionscience.com

ION Science Inc – USA Office

Tel: +1 877 864 7710

Web: <https://ionscience.com/usa/> | Email: info@ionscienceusa.com

ION Science Italy – Italy Office

Tel +39 051 0561850

Web: www.ionscience.com/it | Email: info@ionscience.it

ION Science France – France Office

Tel: +33 613 505 535

Web: www.ionscience.com/fr | Email: info@ionscience.fr

ION Science China – China Office

Tel: +86 21 52545988

Web: www.ionscience.com/cn | Email: info@ionscience.cn

Revision

Date	Revision	Changes
15/05/2025	V1.0	Original user manual
19/09/2025	V1.1	Updates to ARA-X Manager functionality and descriptions, additional information regarding LEL sensors and guidance for use.
26/01/2026	V1.2	Updated conditions of use, PC software images